



Anti-condensing valve with thermostatic control. Connections female.

Working:

The anti-condensing thermic valve optimizes the connection of the solid fuel heating source to the heating system or to the buffer tank, by adjusting automatically the return water temperature to the heating source at the thermostat setting value.

The device keeps the heating source at high temperature (always higher than the condensing temperature) in any working condition, preventing deposits both into the boiler and into the chimney flue, so improving the efficiency and the life. Therefore also corrosion problems of the heating source or dangerous fires of the chimney flues are avoided.

Technical features:

Anti-condensing thermic valve with thermostatic control of the return temperature to solid fuel heating sources. Hot forged brass body. Yellow brass finish.

- Maximum working pressure: 10 bar.
- Maximum temperature: 100°C.
- Calibration temperatures: 45°C, 55°C, 60°C e 72°C.
- Seal: watertight between the A-AB gates; 3% leak rate of Kvs between B-AB gates.
- Easy service or replacement of the sensor to change the calibration without removing the valve from the installation.

PN 10. A-AB kvs value: 7,2. B-AB kvs value: 4,8.
Nominal opening temperature: setting temperature + 10 K.
Available external connections: 1" Female.

FIELD OF UTILIZATION:

For a maximum power that can be managed up to 65 kW (with Δt 20 K) and maximum flow 2800 l/h.

Available calibration temperatures:

45 = 45 °C
55 = 55 °C
60 = 60 °C
72 = 72 °C

Mounting: The valve can be mounted in vertical or horizontal position:

Way of working:

The hydraulic schemes shown here after are related to the use of the thermic valve in mixing mode that, as previously said, allows the optimization of anti-condensing control.

Attention: the following representations show, as exemple, the art. 749. They are to be considered just as an indication and they have no completeness pretension.

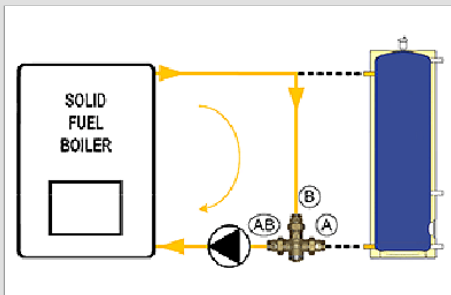

(1) Start of the system (heating of the boiler)

After the starting of the boiler, the thermic valve is fully closed towards the user (**gate A**) and this condition remains until the fluid, warmed up by the heating source, gets the opening temperature of the thermic valve (corresponding to the calibration value, f.i. 55°C). During this step the fluid sent by the boiler fully recycles through the by-pass (**gate B**) and the boiler temperature rises very quickly.

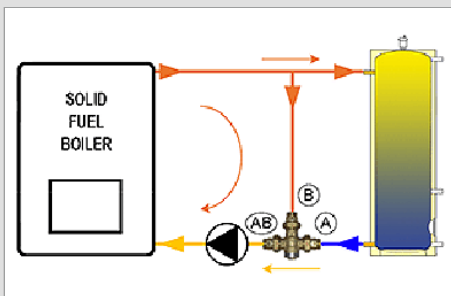

(2) Loading of the system (heating of the tank)

At the achievement of the opening temperature (f.i. 55°C), the way to users (**gate A**) proportionally starts to open meanwhile, the by-pass (**gate B**) is going to be closed. The boiler temperature slowly rises, giving energy to the user but, in any case, it will not decrease any more below the calibration temperature (f.i.55°C).

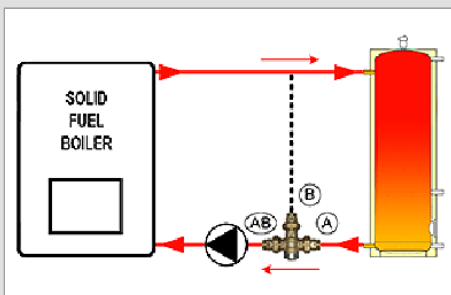

(3) Working system

Starting from the condition of point 2, the supply temperature progressively rises up to the full opening of the thermic valve (**gate A**) and up to the corresponding shutting of by-pass (**gate B**). This happens at about 10 K more than the calibration or opening temperature (therefore, in the example in hand at about 65°C). Now the installation is on working and the supply fluid temperature can rise up to the set value.

Dimensional specifications:

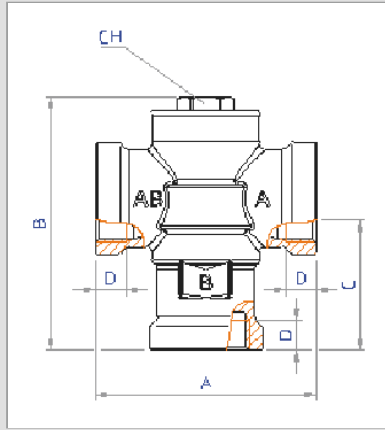

| Specifications | Dimensions |
|----------------|------------|
| A | 1" |
| B | 84 |
| C | 96 |
| D | 57,5 |
| CH | 11,5 |
| Weight [g] | 19 |
| | 720 |

Code 1": **04740-xx**

Code composition: the suffix "xx" shows the setting temperature of the thermic valve; f.i.: **04740-55** (calibration at 55°C)